

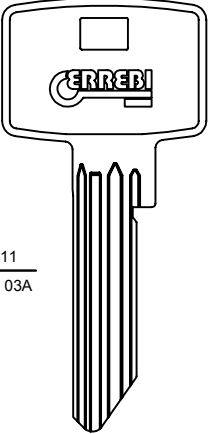









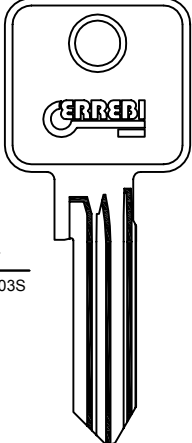

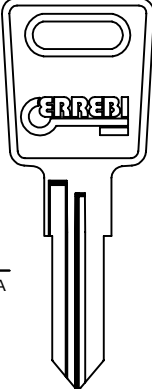

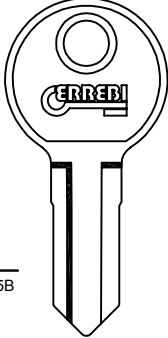

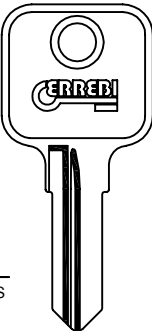
Errebi - news

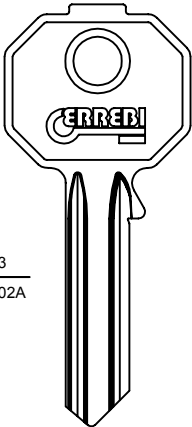
02²⁰¹⁹

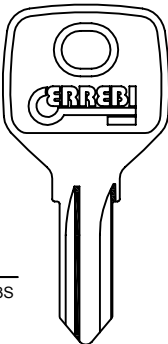
PER/FOR:

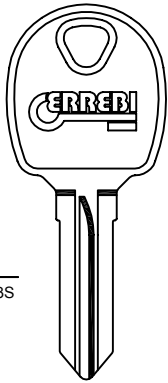
ABUS		HUWIL	ILLINOIS
 <p>611 S 03A</p> <p>A30  AU106</p>	 <p>S 03S</p> <p>C83  AU107</p>	 <p>226 S 03A</p> <p> UW12R</p>	 <p>S 05B</p> <p> ILL1</p>
OJMAR	PREFER	RONIS	
 <p>S 03S</p> <p> OJ26R</p>	 <p>23 B 02A</p> <p> P19</p>	 <p>S 03S</p> <p>CA  R40</p>	 <p>S 03S</p> <p> R41</p>

ABUS (DE)
HUWIL (DE)
ILLINOIS (US)
OJMAR (ES)
PREFER (IT)
RONIS (FR)

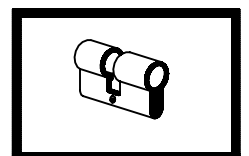

1

Errebi - news

02²⁰¹⁹

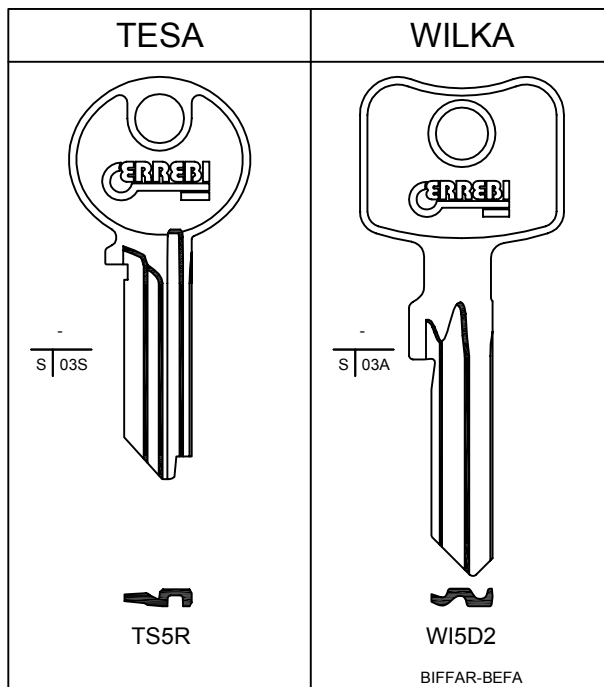

PER/FOR:

TESA (ES)
WILKA (DE)

ERREBI

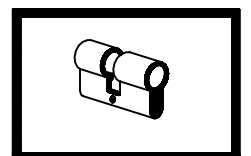

2

Errebi - news

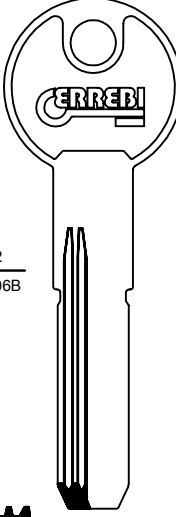
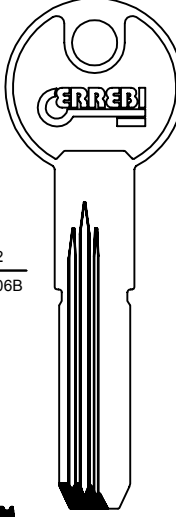
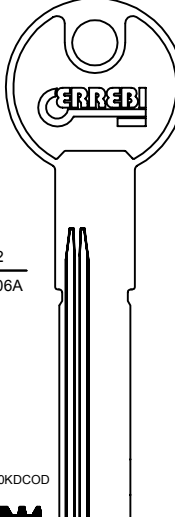
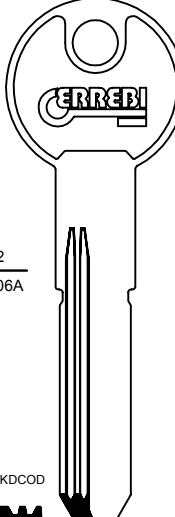
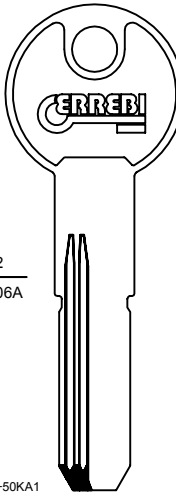
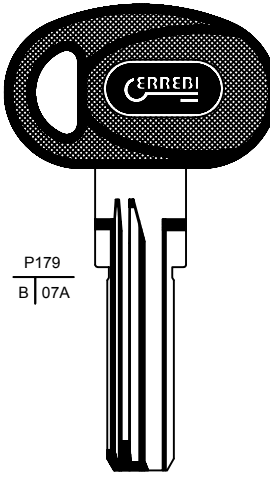
DIAMOND		MOIA	
 <p>12 B 06B</p> <p>DI2</p>	 <p>12 B 06B</p> <p>DI3</p>	 <p>12 B 06A</p> <p>H30+30KDCOD</p> <p>MA6</p>	 <p>12 B 06A</p> <p>H50+30KDCOD</p> <p>MA7</p>
MASTER LOCK			
	<p>MOIA</p>  <p>12 B 06A</p> <p>H30+50KA1</p> <p>MA8</p>	<p>MOTTURA</p>  <p>P179 B 07A</p> <p>MO3P179</p>	

PER/FOR:

DIAMOND (TW)
MOIA (IT)
MOTTURA (IT)

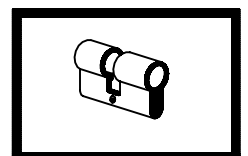

3

AGA

PER/FOR:

AGA (ES)

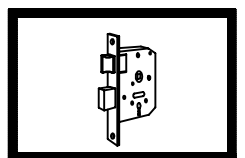
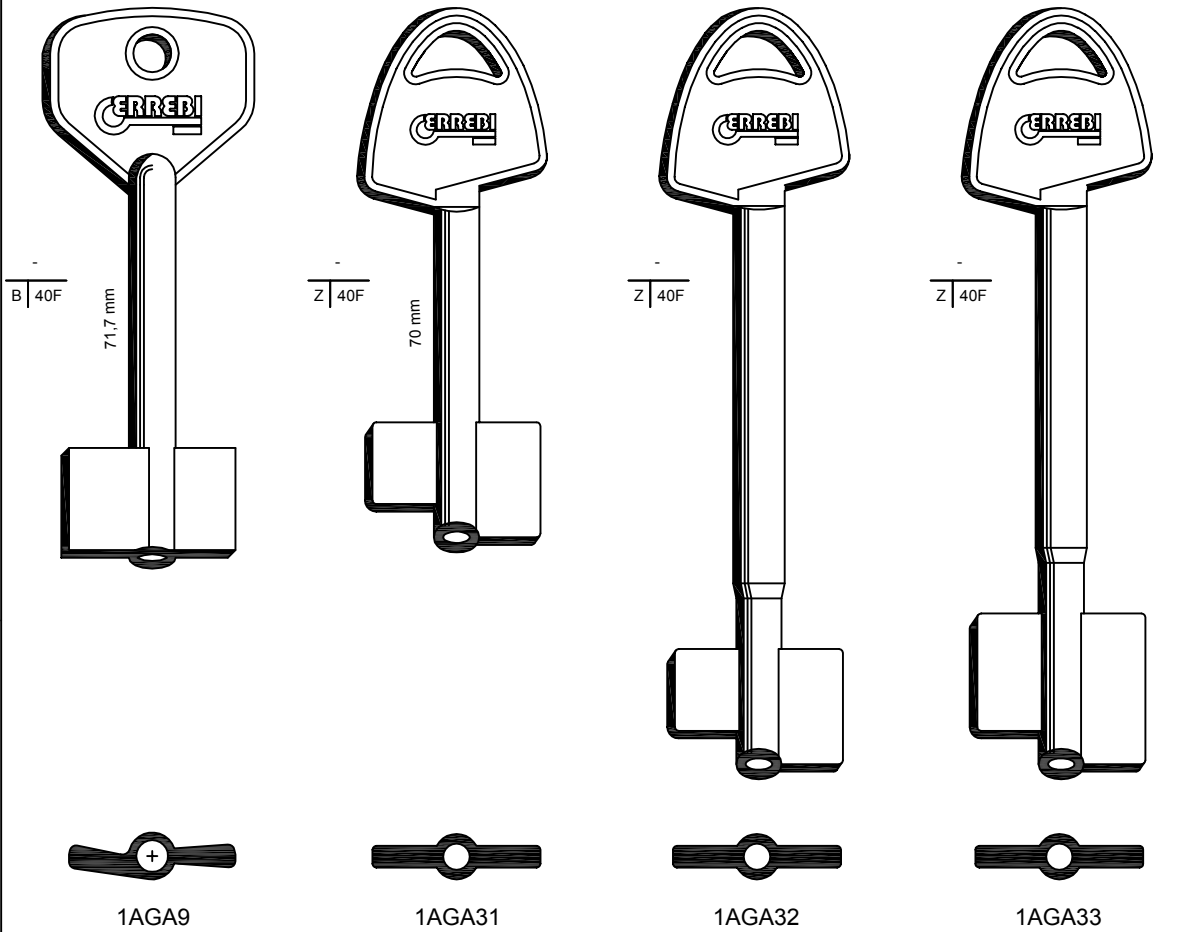

Errebi - news

02²⁰¹⁹

AGA

PER/FOR:

AGA (ES)

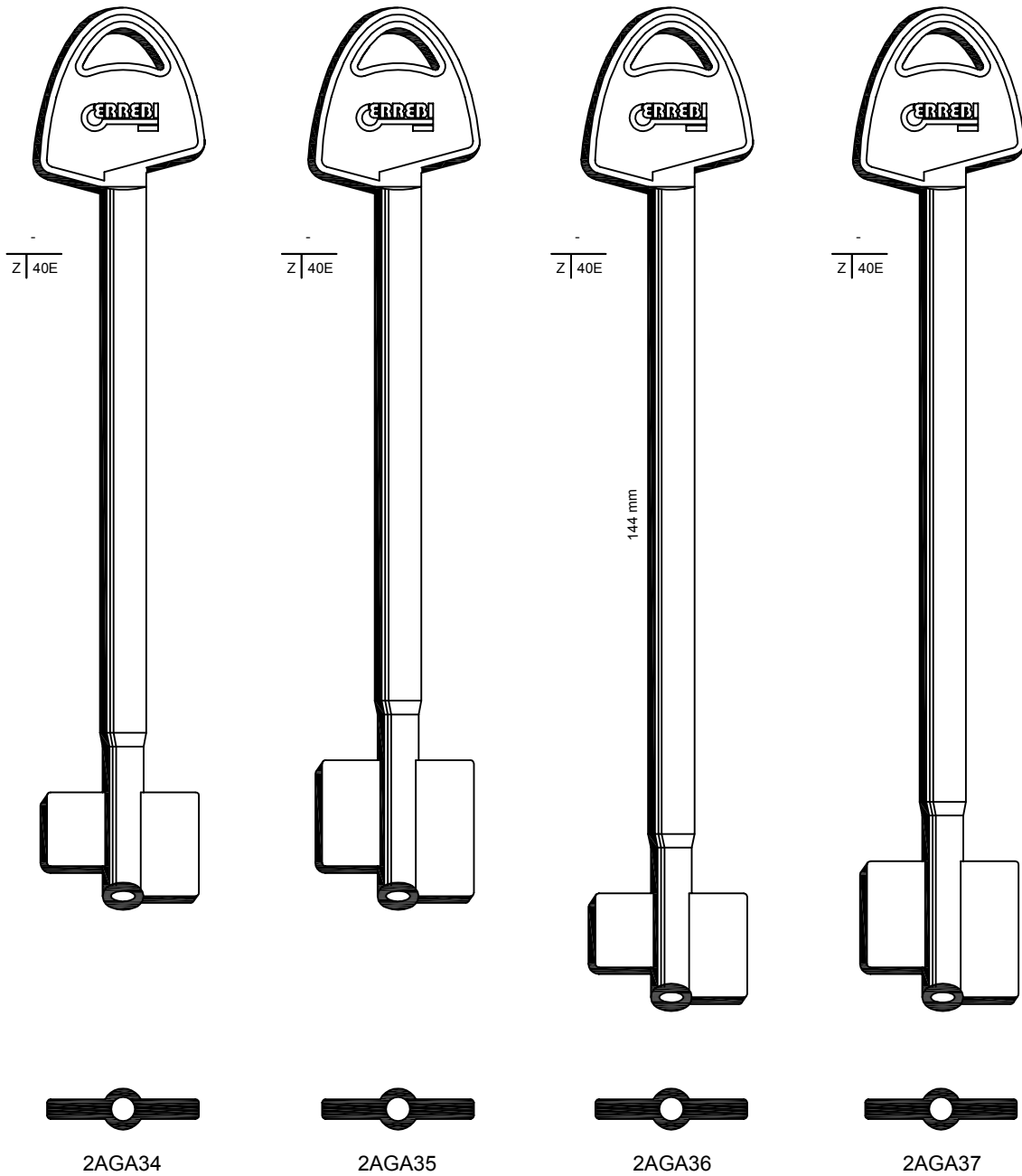

ERREBI

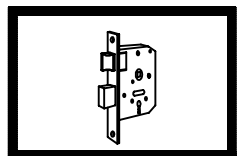

5

Errebi - news

02²⁰¹⁹

AGA

PER/FOR:

AGA (ES)

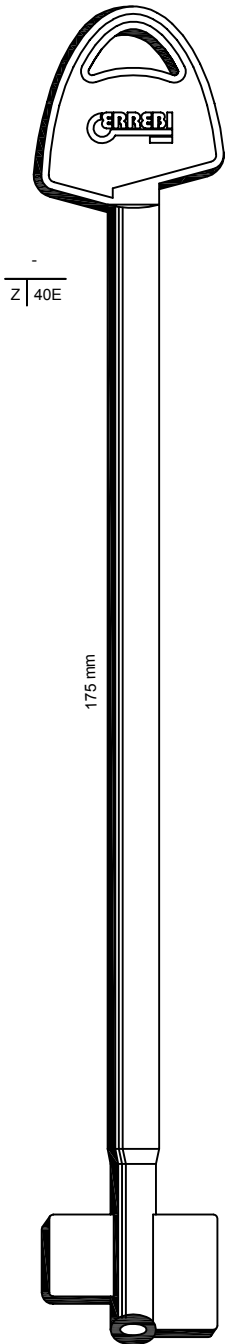

2AGA38

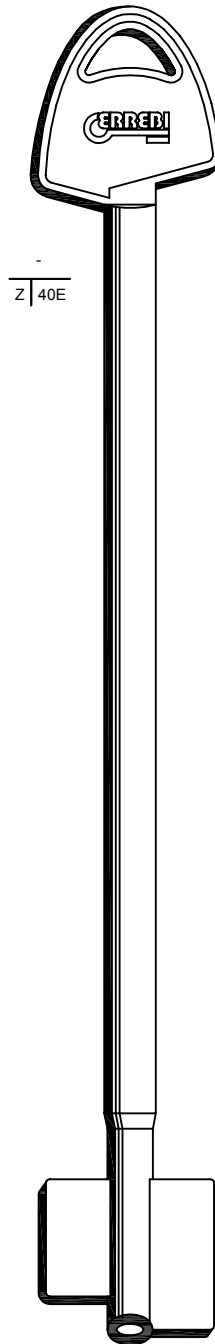

2AGA39



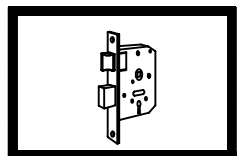





ERREBI



6

Errebi - news

02 2019

GIOBERT	HUF	ISUZU	KTM
 <p>P B 21B</p>  <p>GB18P</p>	 <p>P B 21B</p> <p>...1-4000</p>  <p>HF65P3</p>	 <p>P S 20A</p>  <p>ISU8P</p>	 <p>P B 21B</p>  <p>KM1P</p>

PER/FOR:

GIOBERT (IT)
HUF (DE)
ISUZU (KR)
KTM (AT)

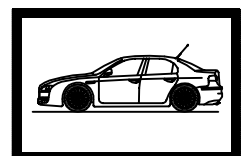

ERREBI



7

Errebi - news

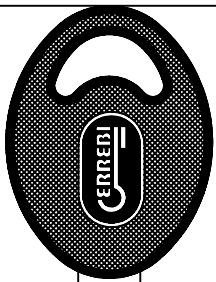
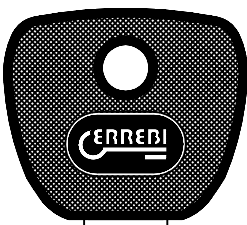
Chiavi fuori produzione

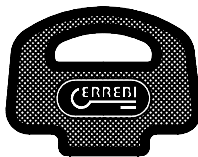
G.M.	HUF	HYUNDAI	SUZUKI
 <p>P111 B 21F</p> <p>1... 1-5000</p> <p>GM24RP111 TOKAJ-RIKA</p>	 <p>P8 S 20A</p> <p>28.4 mm.</p> <p>HB... 10001-20000</p> <p>HFHBLP8</p>	 <p>P107 S 20A</p> <p>X... 1001-2000</p> <p>HYN3RP107</p>	 <p>P31 S 20A</p> <p>.... 101-499 751-795 A00-A98</p> <p>SZ1P31 HONDA-KAWASAKI</p>

PER/FOR:



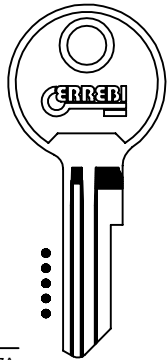

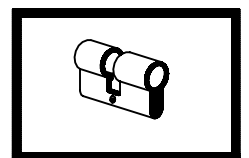
GENERAL
MOTORS (US)
HUF (DE)
HYUNDAI (KR)
SUZUKI (JP)
YALE-USA (US)

YALE-USA
 <p>33 S 17A</p> <p>YU3R BENDIX-CHICAGO-FORT-ILLINOIS</p>

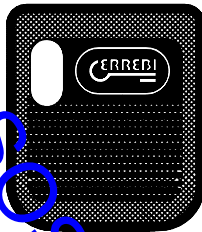

Errebi - news

Chiavi sostituite da nuovo modello

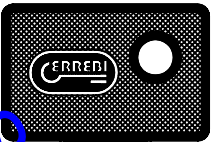
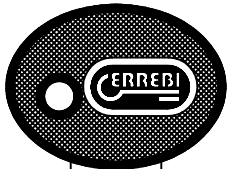
MOIA		ISUZU	
 P65 B 07A MA6P65	 12 B 06A H30+30KDCOD MA6	 P49 S 20A ISU8P49	 P S 20A ISU8P
SIPEA			
 P39 S 20A F SPFP39	 P S 20S F SPFP		

PER/FOR:

MOIA (IT)
ISUZU (KR)
SIPEA (IT)

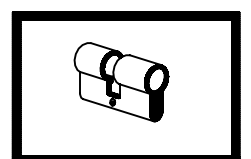

9